

1121.006 - GRBLUEP 200/2/G40H A1CT5 NGNAB51040NWOCX

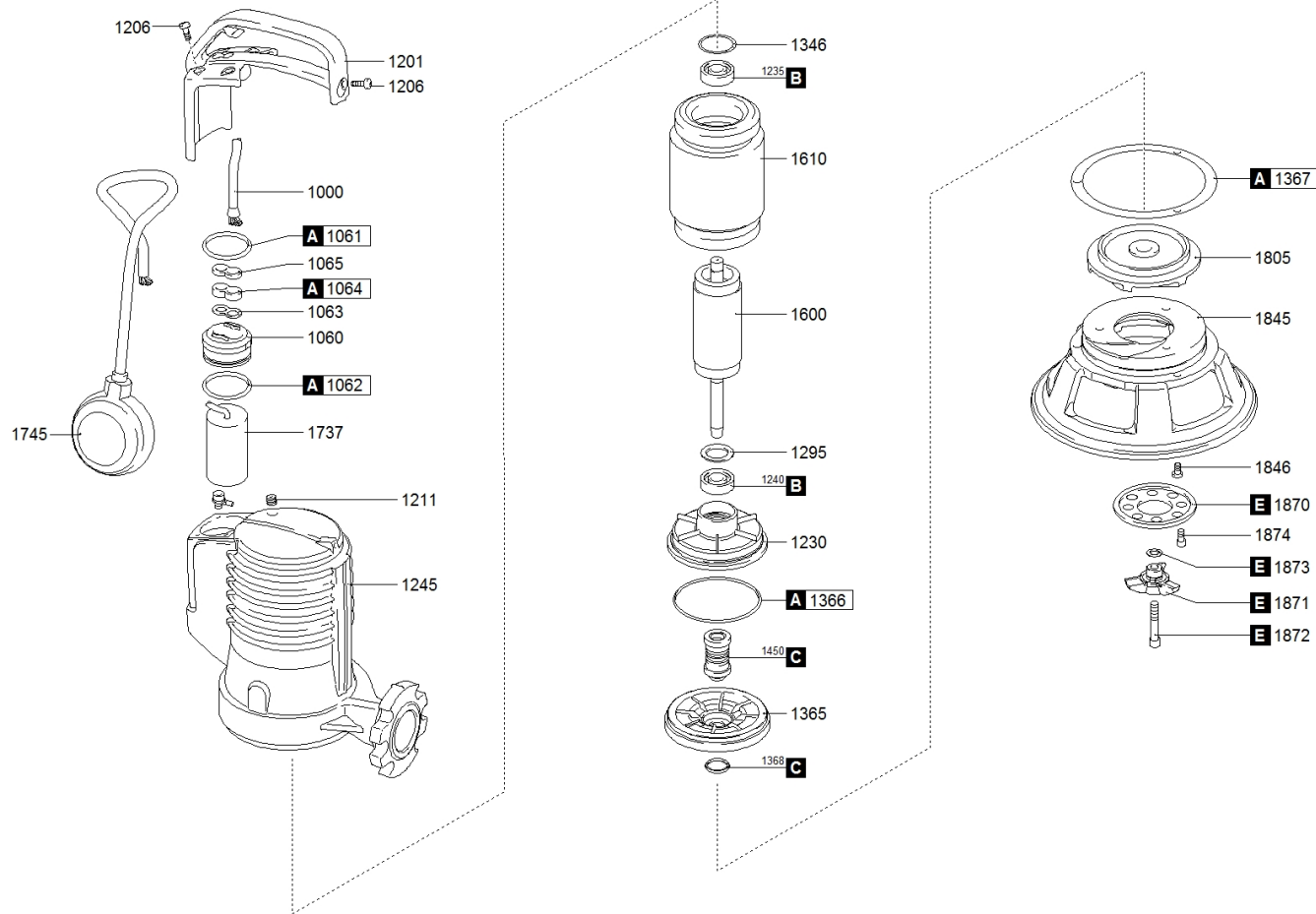

BluePRO 107
GR G40H 01A



water solutions



1121.006 - GRBLUEP 200/2/G40H A1CT5 NGNAB51040NWOCX

		Code		Description		Q.ty	Price (€)
A		601008001		GASKETS KIT	801156	1	
C		602008051		MECHANICAL SEALS KIT	711038	1	
E		603008001		CUTTING SYSTEM KIT	801140	1	
1000		250102404010000000		POWER CABLE		1	
1060		239768026156		HOLDER [CABLE GLAND]	805885	1	
1061		271770412835300000		UPPER GASKET - HOLDER [CABLE GLAND]	711030	1	
1062		271770040952620000		LOWER GASKET - HOLDER [CABLE GLAND]		1	
1063		235467024280		CABLE STOP		2	
1063		2732001100000		CABLE STOP		1	
1064		235678024238		RUBBER GASKET		1	
1065		235467024241		CABLE GLAND	805884	1	
1201		235361024325		CABLE GLAND HANDLE	804984	1	
1206		270830510140400000		SCREW [CABLE GLAND HANDLE >> COVER]		5	
1211		270139510104000000		CAP [TIGHTNESS TEST]	802099	1	
1230		230556323604		LOWER BEARING HOLDER		1	
1235		2729062030200000		UPPER BEARING	711360 or 802083	1	
1240		2729063050400000		LOWER BEARING	710969	1	
1245		231016324969		MOTOR CASE		1	
1295		270220250352000000		UPPER DISTANCE RING [LOWER BEARING]	802311	1	
1346		27542039100000		WAVE SPRING	802283	1	
1365		2391120025023609		MECHANICAL SEAL FLANGE		1	
1366		271770107035000000		GASKET [LOWER BEARING HOLDER >> MECHANICAL SEAL FLANGE]		1	
1367		2750914423934		GASKET [MECHANICAL SEAL FLANGE >> BASE]		5	
1368		237970160220600000		V-RING [MECHANICAL SEAL FLANGE]		1	
1450		230005040180000000		MECHANICAL SEAL	802308	1	
1600		230233612023760		SHAFT WITH ROTOR		1	
1610		231101203002000000		WOUND STATOR	711330 or 802369	1	
1805		21411501000523670		IMPELLER	805771	1	
1845		2145114423590		BASE	804669	1	
1846		270830610203200000		SCREW [BASE >> MOTOR CASE]		3	
1870		211720624144		CUTTING DISK		1	
1871		211630824027		CHOPPER KNIFE		1	
1872		270830610453200000		LOCKING CHOPPER KNIFE		1	
1873		270620120180200000		WASHER [CHOPPER KNIFE]	711051	4	
1874		270830610123200000		SCREW [CUTTING DISK >> PUMP BODY]	802092	3	

